



PRODUCT SPEC SHEET BOOKLET

Collection of Our Hoist System
and Truck Bodies

AUGUST 2023



Subsidiary of Federal Signal Corporation

Interchangeable Truck Body System

HOIST SYSTEM

Patent: US 11,214,186 B2



Body Hold Downs

Universal design to secure multiple body lengths* with one system

*Bodies must be system length or shorter



Hook Storage

Integrated cable hook stowing on both sides of system



Pendant Control

Simple design for single-handed operation



Swivel Hook

Reduces cable stiffness for improved cable spooling and body attachment



Slide Pads

Provide low friction body support and reduced wear on the system/body rails



Body Rollers

Single piece, pre-lubricated and bolt-on design for smooth rolling



Electronics System

Fully enclosed and waterproof junction box with an IP 66 rating



V Roller

Poly material to reduce excessive wear and extends cable life



Pump Cover

Provides additional protection to the pump



H SERIES

HOIST SYSTEM

H Series is a full hydraulic hoist system built for heavy duty workloads and is ideal for class 5-7 chassis cab vehicles with a GVWR of 16,001lbs-33,000lbs.

18,000 lbs 15,000 lbs



| Model Name | Dumping Capacity (tons) | Minimum CEF (in.) | Winch Capacity (lbs) | Overhang Length (in.) | Typical CA (in.) |
|-----------------|-------------------------|-------------------|----------------------|-----------------------|------------------|
| 11-4016-15H-10T | 10.3 | 132" (11') | 15,000 | 18" | 84"-96" |
| 11-5020-18H-14T | 14 | 132" (11') | 18,000 | 18" | 84"-96" |
| 14-5020-18H-10T | 10.3 | 168" (14') | 18,000 | 18" | 120"-138" |

Specifications are subject to change without notice. The Gross Vehicle Weight (GVW) or Gross axle weight rating (GAWR) will limit the operating capacity of the vehicle upfitted with a hoist system. For Switch-N-Go* product warranty information, please refer switchngo.com/warranty.

OPTIONS

- Wireless Remote
- Compatible Gooseneck

FEATURES

- Ideal for chassis cab vehicles with a GVWR of 13,500-33,000lbs
- Compatible with vehicles ranging from 60" CA to 138" CA
- Bolt on design allows for easy transfer between chassis
- Easy single handed operator controls with in-cab and on-hoist connection points
- Variety of dump capacities up to 14 tons



E SERIES

HOIST SYSTEM

E Series is an electric powered hydraulic hoist system built for medium duty workloads and is ideal for class 4-7 chassis cab vehicles with a GVWR of 13,500lbs-26,000lbs. The system is designed to handle six fully loaded winch draws per day.*

15,000 lbs



| Model Name | Dumping Capacity (tons) | Minimum CEF (in.) | Winch Capacity (lbs) | Overhang Length (in.) | Typical CA (in.) |
|-----------------|-------------------------|-------------------|----------------------|-----------------------|------------------|
| 10-4016-15E-11T | 10.8 | 120" (10') | 15,000 | 18" | 72"-84" |
| 11-4016-15E-10T | 10.3 | 132" (11') | 15,000 | 18" | 84"-96" |
| 11-4020-15E-12T | 12.6 | 132" (11') | 15,000 | 18" | 84"-96" |
| 11-5020-15E-14T | 14.0 | 132" (11') | 15,000 | 18" | 84"-96" |
| 12-4020-15E-11T | 11.3 | 144" (12') | 15,000 | 18" | 96"-108" |
| 13-4020-15E-10T | 10.3 | 156" (13') | 15,000 | 18" | 108"-120" |
| 14-4020-15E-9T | 9.3 | 168" (14') | 15,000 | 18" | 120"-138" |
| 14-5020-15E-10T | 10.3 | 168" (14') | 15,000 | 18" | 120"-138" |

* A fully loaded winch draw is equal to the rating of the winch, which is 15,000lbs. If you are loading 15,000lbs (body and payload), the system can pull six loads per day. If you are loading a lesser weight, the system will be able to pull more than six loads per day. For example, if your load is 10,000lbs (body and payload), the system can pull approximately 10 loads per day.

* Refer to your vehicle operator guide for manufacturer recommendations on GVWR.

- Hoist System can raise up to 50° dump angle
- Strong, lightweight system to maximize truck payload
- Self-engaging front body lock to secure body during transport and dumping



Interchangeable Truck Body System

Subsidiary of Federal Signal Corporation

DUMP BODY

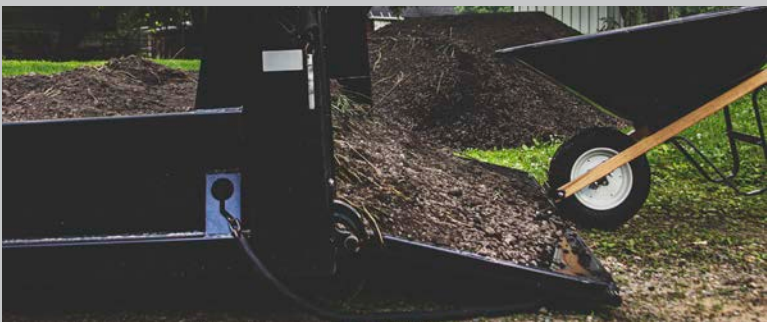

FEATURES

- High quality zinc prime & powder coated finish
- Ramp gate for drive-on convenience
- Accepts underbody salt spreader
- 12" side height & 24" tailgate height
- Optional extended board pockets
- Standard 6" steel dump body ground rollers
- Custom options available

FIND A DEALER IN YOUR AREA

SWITCHNGO.COM/DEALER

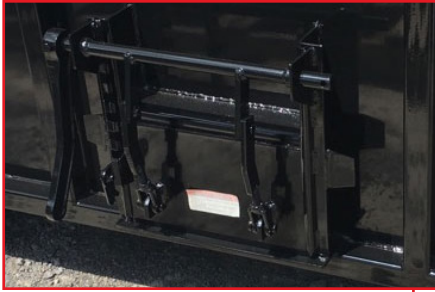

Coal Chute
(optional)



18" Cab Shield
(optional)

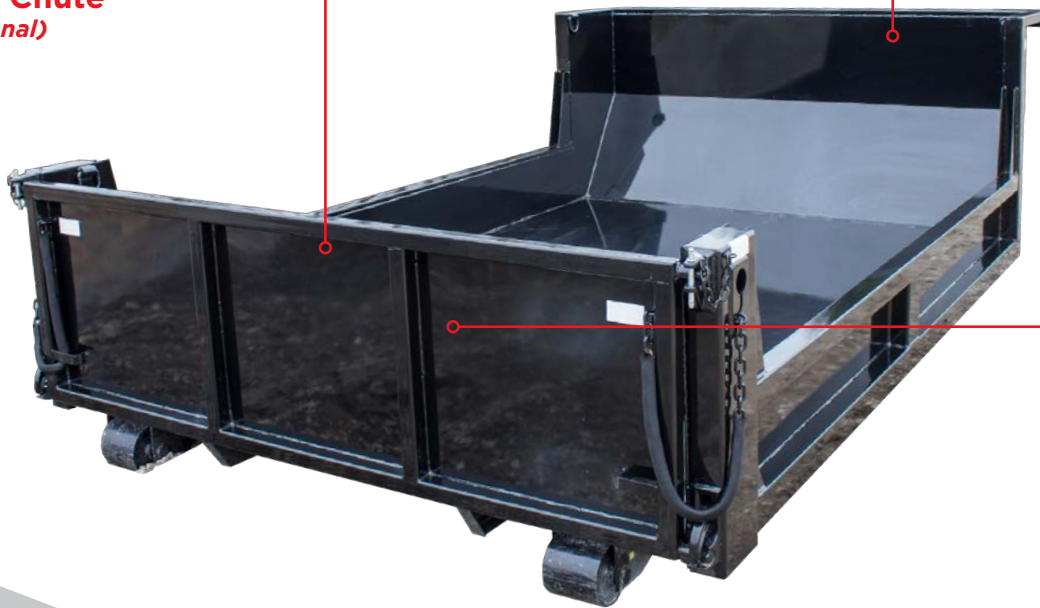

Double Acting Tailgate

SPECIFICATIONS

| | STANDARD DUTY | HEAVY DUTY |
|---------------------|--|--|
| FLOOR | 10 GA STEEL | 3/16" STEEL |
| CROSSMEMBERS | 3" STRUCTURAL CHANNEL 16" ON CENTER | 3" STRUCTURAL CHANNEL 12" ON CENTER |
| SIDE | 12 GA STEEL | 10 GA STEEL |
| TOP RAIL | 3" X 3" X 1/8" TUBING | |
| BULKHEAD | INSIDE HEIGHT 39", 44", OR 51" | |
| TAILGATE | 2" X 2" X 3/16" TUBING & 10 GA SHEET | |
| OPTIONS | DROP DOWN SIDES / 18" CAB SHIELD / COAL CHUTE / WELDED D-RINGS | |

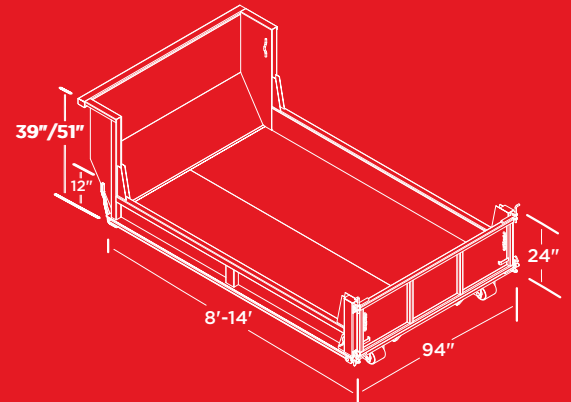

Specifications are subject to change without notice. For warranty information on this or any other Switch-N-Go® product please refer switchngo.com/warranty.



Subsidiary of Federal Signal Corporation

Interchangeable Truck Body System

ALUMINUM DUMP BODY

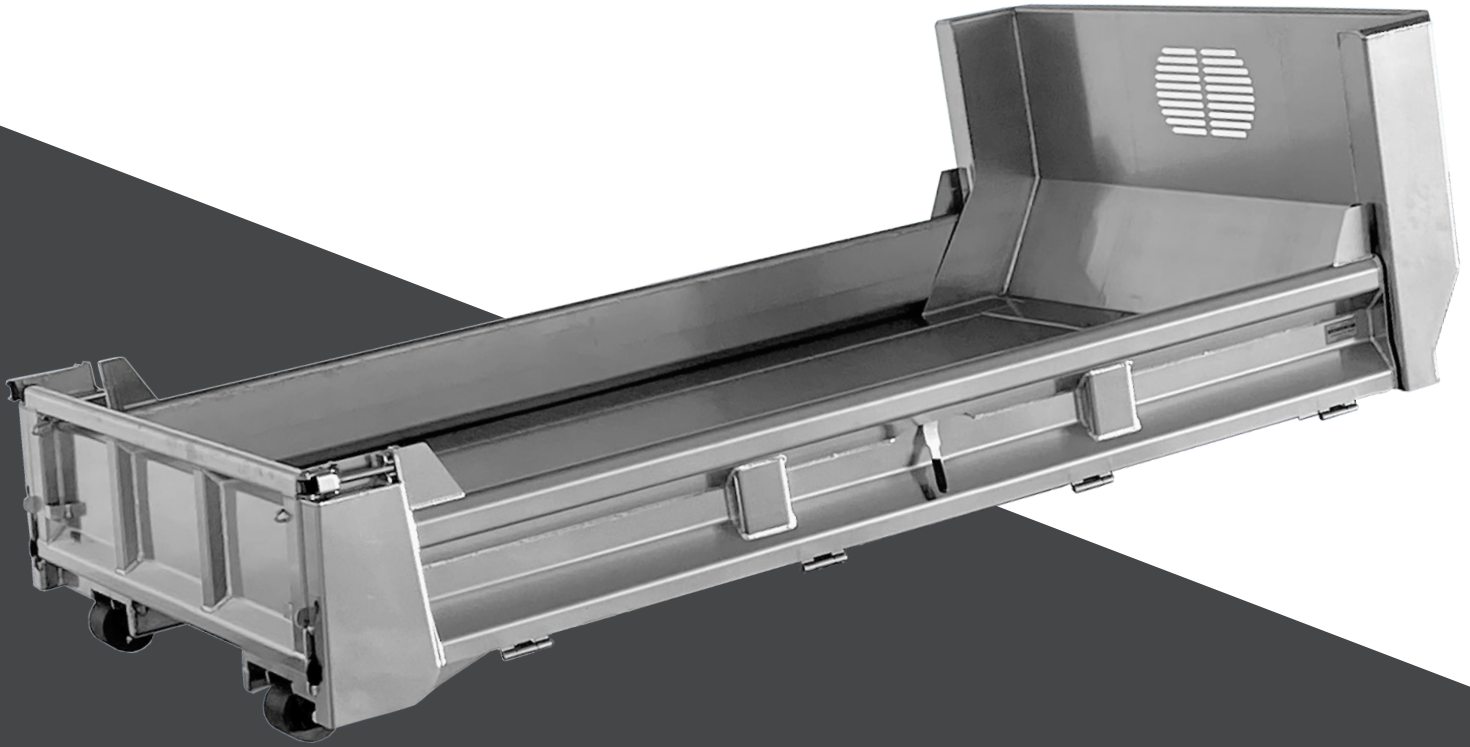

FEATURES

- Lightweight build for additional payload
- Superior corrosion resistance
- Double acting ramp/dump gate
- Manual front release tailgate
- Single piece floor
- Double walled sides
- Compatible with 11' Switch-N-Go® hoist systems

FIND A DEALER IN YOUR AREA

SWITCHNGO.COM/DEALER

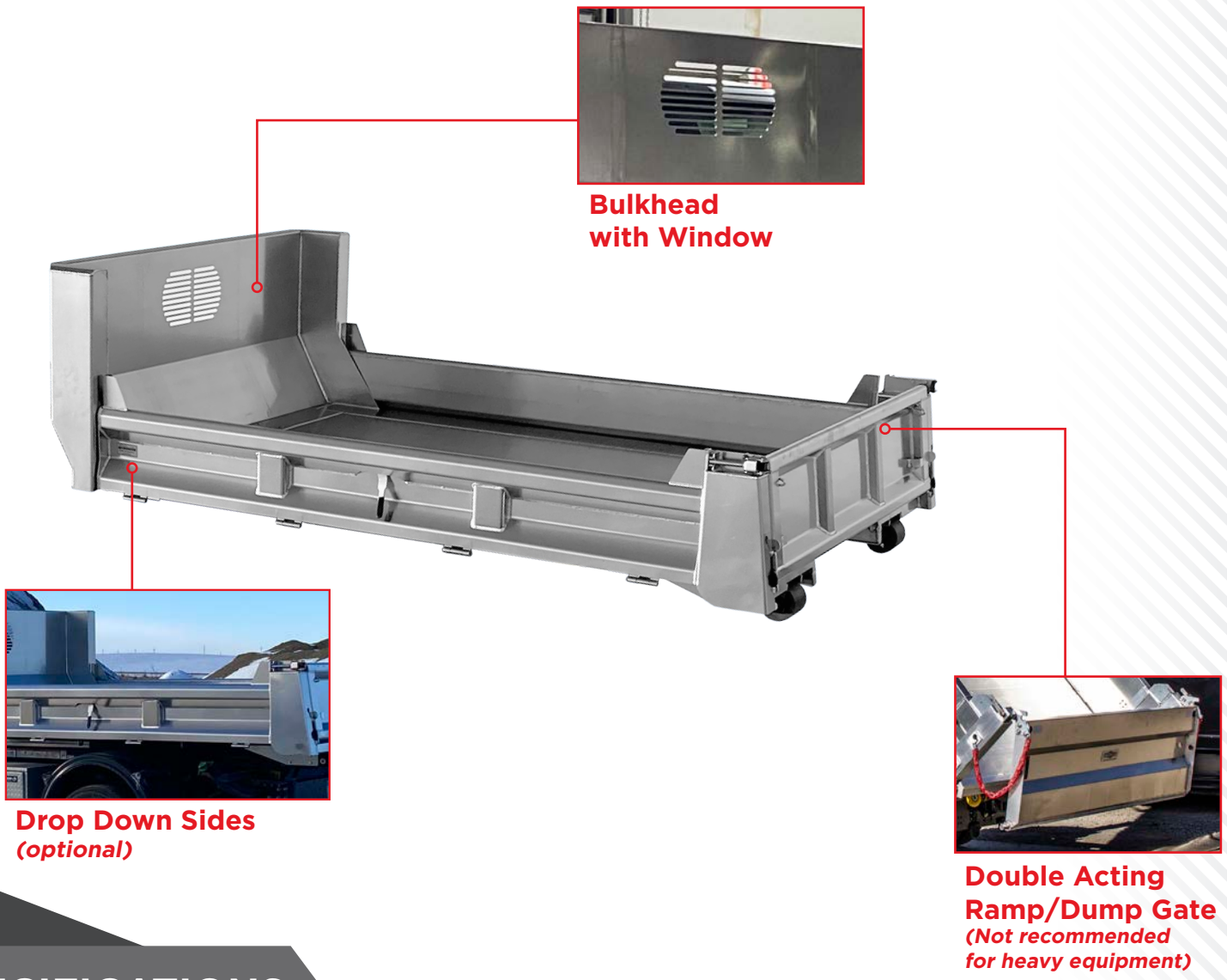

Bulkhead with Window

Drop Down Sides (optional)

Double Acting Ramp/Dump Gate (Not recommended for heavy equipment)

SPECIFICATIONS

| | BODY DETAILS |
|----------------------|---|
| FLOOR | 5052 ALUMINUM (1/4") |
| CROSS MEMBER SPACING | 3" I-BEAMS ON 14 3/4" CENTERS |
| SIDES/FRONT/TAILGATE | 5052 ALUMINUM |
| TAILGATE HEIGHT | 18" |
| SIDE HEIGHT | 12" |
| BULKHEAD | INSIDE HEIGHT 38" WITH WINDOW (48" FOR HIGH TRUCK CABS) |
| BOARD POCKET HEIGHTS | TAILGATE/BULKHEAD: 6" |
| VOLUME | 3 CUBIC YARDS |
| OPTIONS | FOLD DOWN SIDES |

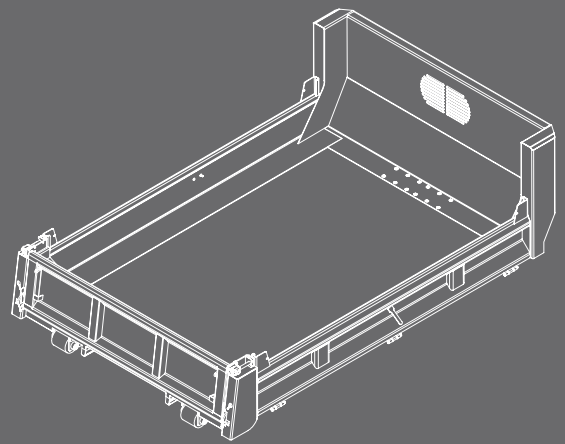

Specifications are subject to change without notice. For warranty information on this or any other Switch-N-Go® product please refer switchngo.com/warranty.



Subsidiary of Federal Signal Corporation

Interchangeable Truck Body System

STAINLESS STEEL DUMP BODY



FEATURES

- Superior Corrosion Protection
- Double Acting Tailgate
- Manual Front Release
- Bottom Painted Black

FIND A DEALER IN YOUR AREA

SWITCHNGO.COM/DEALER



Manual Front Release



Double Acting Tailgate



Drop Down Sides (optional)

SPECIFICATIONS

| | |
|-----------------------------|--|
| | 11' |
| FLOOR | 10 GA 304 STAINLESS STEEL |
| SIDES/FRONT/TAILGATE | 10 GA 304 STAINLESS STEEL |
| TAILGATE HEIGHT | 26" |
| SIDE HEIGHT | 14" |
| BULKHEAD | INSIDE HEIGHT 39" OR 51" |
| BOARD POCKETS | 6" HIGH |
| D-RINGS | 1 ON EACH CORNER |
| OPTIONS | DROP DOWN SIDES / 18" CAB SHIELD / COAL CHUTE / WELDED D-RINGS |
| HOIST COMPATIBILITY | 11' |

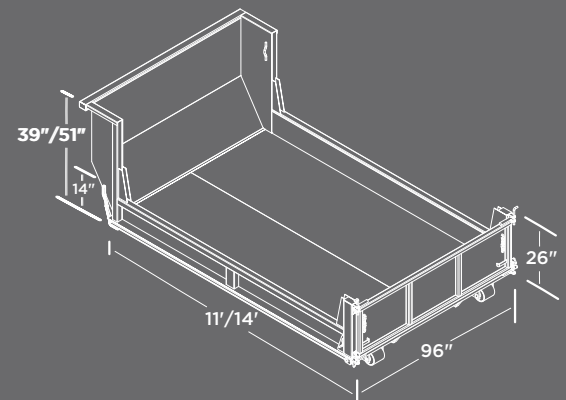

Specifications are subject to change without notice. For warranty information on this or any other Switch-N-Go® product please refer switchngo.com/warranty.



Interchangeable Truck Body System

Subsidiary of Federal Signal Corporation

DROP BOX



FEATURES

- High quality zinc prime & powder coated finish
- Two build grades available
- Standard 6" steel ground rollers
- Optional curb side door
- Custom options available

FIND A DEALER IN YOUR AREA

SWITCHNGO.COM/DEALER

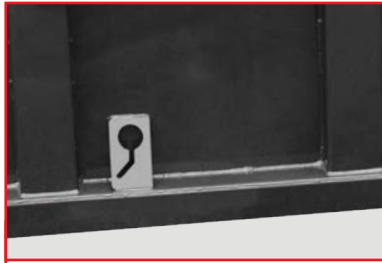

Keychain Brackets



**Curbside Door
(optional)**



**Available in
Single Swing
or Barn Doors**



SPECIFICATIONS

| | MEDIUM DUTY | HEAVY DUTY |
|-----------------------------|--|--|
| FLOOR | 10 GA | 3/16" |
| SIDE POSTS | 2-3 POSTS PER SIDE, 12 GA SHEET | 30-36" ON CENTER POSTS, 12 GA SHEET |
| CROSSMEMBERS | 3" STRUCTURAL CHANNEL, 16" ON CENTER | 3" STRUCTURAL CHANNEL, 12" ON CENTER |
| TOP RAIL | 3" X 3" X 1/8" TUBING | |
| TAILGATE | 3" STRUCTURAL CHANNEL, 16" ON CENTER | |
| SIDE HEIGHTS | 39" & 51" | 36" & 48" |
| SIDES/FRONT/TAILGATE | 12 GA SHEET | |
| REAR CORNER POST | 7 GA SHEET | |
| OPTIONS | CURBSIDE DOOR / WELDED D-RINGS CAB SHIELD | |

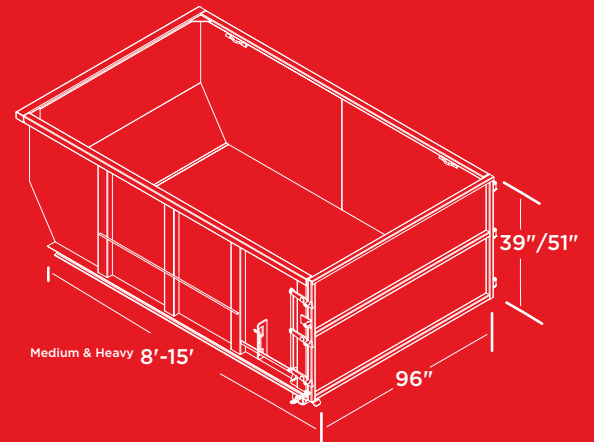

Specifications are subject to change without notice. For warranty information on this or any other Switch-N-Go® product please refer switchngo.com/warranty.



Subsidiary of Federal Signal Corporation

Interchangeable Truck Body System

DUMPSTER BODY



FEATURES

- Structural steel construction
- Bodies are powder coated
- Body widths are 88" inside and 96" outside
- Interior side heights are 51" or 53", depending on the style chosen
- Standard 6" steel ground rollers

FIND A DEALER IN YOUR AREA

SWITCHNGO.COM/DEALER



FORMED
TOP RAIL



3"x3" TUBING
TOP RAIL

SPECIFICATIONS

| | FORMED TOP RAIL | TUBING TOP RAIL |
|---------------------------------------|--|-----------------------|
| TOP RAIL | FORMED TOP RAIL | 3" X 3" X 1/8" TUBING |
| SIDE HEIGHT | 53" | 51" |
| CROSSMEMBERS | FORMED 3" CROSSMEMBERS ON 18" CENTERS | |
| TAILGATE | 2" X 2" X 1/8" TUBING TUBULAR FRAME WORK SINGLE SWING GATE | |
| SIDES/FRONT/TAILGATE | 12 GA SHEET | |
| REAR CORNER POST | 12 GA SHEET | |
| FLOOR | 12 GA SHEET | |
| OPTIONS | NONE | |
| AVAILABLE SIZES | 11' / 12' / 14' | 11' / 12' / 14' |
| APPROXIMATE HEAPED CUBIC YARDS | 15 / 16 / 20 | 14 / 15 / 17 |
| WEIGHT (LBS) | 2030 / 2160 / 2380 | 2080 / 2210 / 2440 |

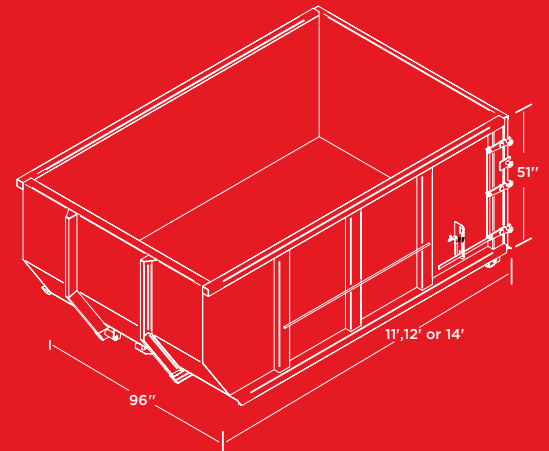

Black powder or wet paint. No seam seal or options. May be produced in two different production facilities Location will be confirmed when ordering shipment.

Specifications are subject to change without notice. For warranty information on this or any other Switch-N-Go® product please refer switchngo.com/warranty.



Interchangeable Truck Body System

Subsidiary of Federal Signal Corporation

ARBOR BODY WITH SECTIONAL REMOVABLE ROOF*

* One Piece Removable Roof Also Available



51" side height and 39" SS tailgate pictured



FEATURES

- High quality zinc prime & powder coated finish
- Removable sectional roof - mounting hardware included
- Standard 6" steel ground rollers

FIND A DEALER IN YOUR AREA

SWITCHNGO.COM/DEALER

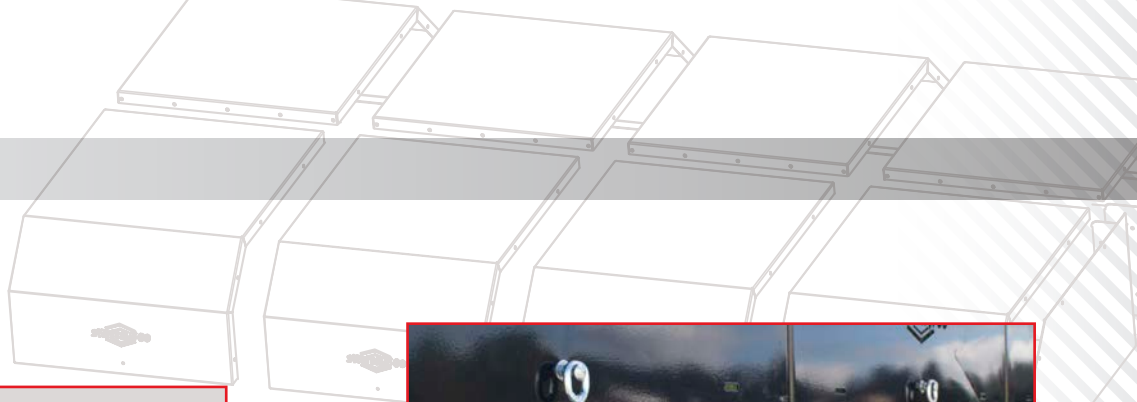

24" Rear Cover Plate
(Optional)

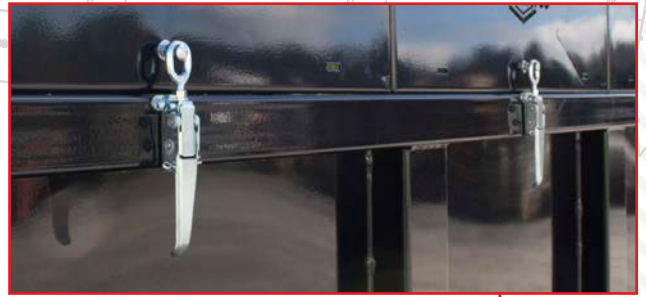

Cam-Latches for simple removal of some or all roof sections



Single Swing or Barn Doors
(Not available on 8' MDRB models)



SPECIFICATIONS

Assembly Required - Factory Install Not Available

| MEDIUM DUTY | |
|---------------------------------|---|
| FLOOR | 10 GA |
| SIDE POSTS | 2-3 POSTS PER SIDE, 12 GA SHEET |
| TAILGATE | 2" x 2" x 1/8" TUBING TUBULAR FRAME WORK FORMED 12 GA SHEET |
| TOP RAIL | 3" x 3" x 1/8" TUBING |
| SECTIONAL REMOVABLE ROOF | 12 GA SHEET 22" HIGH WITH TOP SUPPORT 37" LONG SECTIONS - ALSO AVAILABLE INDIVIDUALLY 2" x 2" x 1/8" AND 8" ANGLE EDGE MESH VENTS ON BOTH SIDES |
| BULKHEAD | 12 GA SHEET |
| OPTIONS | 24" REAR COVER PLATE, BARN DOORS AVAILABLE FOR 39" GATES |

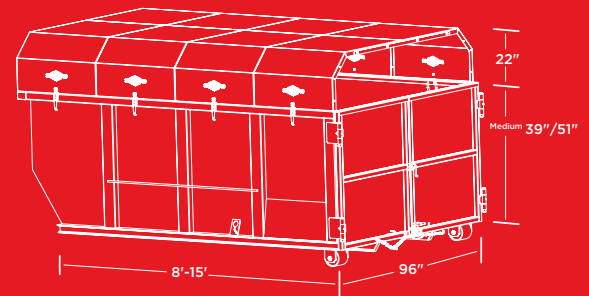

Specifications are subject to change without notice. For warranty information on this or any other Switch-N-Go® product please refer switchngo.com/warranty.



Interchangeable Truck Body System

Subsidiary of Federal Signal Corporation

ARBOR BODY WITH ONE PIECE REMOVABLE ROOF*

* Sectional Removable Roof Also Available



51" side height and 39" BD tailgate pictured

ALSO AVAILABLE WITH A SECTIONAL REMOVABLE ROOF



FEATURES

- High quality zinc prime & powder coated finish
- One piece roof bolted onto Arbor Body
- Standard 6" steel ground rollers



FIND A DEALER IN YOUR AREA

SWITCHNGO.COM/DEALER



24" Rear Cover Plate
(Optional)



One Piece Roof bolted onto Arbor Body



Single Swing or Barn Doors
(Not available on 8' MDRB models)

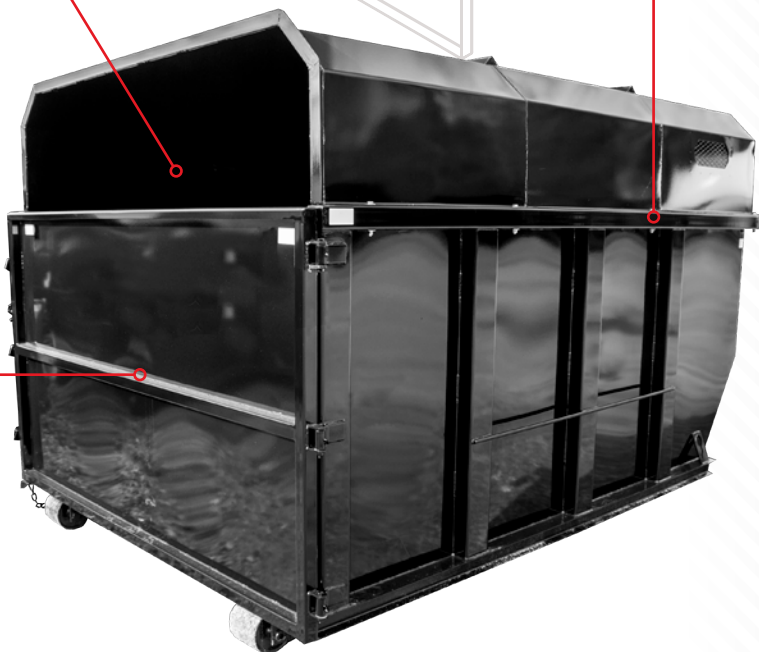

SPECIFICATIONS

MEDIUM DUTY

| | |
|-----------------------|---|
| FLOOR | 10 GA |
| SIDE POSTS | 2-3 POSTS PER SIDE, 12 GA SHEET |
| TAILGATE | 2" x 2" x 1/8" TUBING TUBULAR FRAME WORK FORMED 12 GA SHEET |
| TOP RAIL | 3" x 3" x 1/8" TUBING |
| ONE PIECE ROOF | 12 GA SHEET 22" HIGH WITH TOP SUPPORT 37" LONG SECTIONS - ALSO AVAILABLE INDIVIDUALLY 2" x 2" x 1/8" AND 8" ANGLE EDGE MESH VENTS ON BOTH SIDES (1/SIDE FOR 8'-11' LENGTHS, 2/SIDE FOR 12'-15' LENGTHS) |
| BULKHEAD | 12 GA SHEET |
| OPTIONS | 24" REAR COVER PLATE, BARN DOORS AVAILABLE FOR 39" GATES |

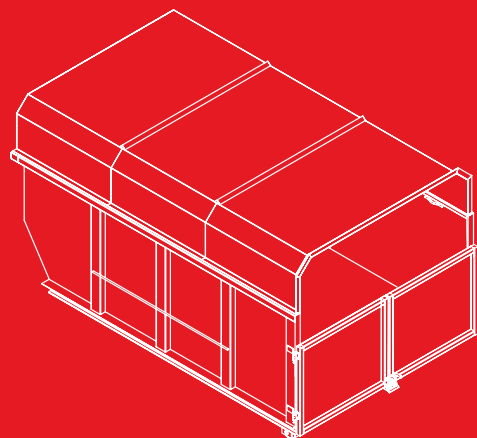

Specifications are subject to change without notice. For warranty information on this or any other Switch-N-Go® product please refer switchngo.com/warranty.



Subsidiary of Federal Signal Corporation

Interchangeable Truck Body System

FLATBED



FEATURES

- High quality zinc prime & powder coated finish
- Lightweight design
- 24" on center stake pockets
- Lasercut window in bulkhead
- 4-Corner chain keyholes
- Low profile 4" steel ground rollers
- Custom options available

FIND A DEALER IN YOUR AREA

SWITCHNGO.COM/DEALER



Corner Key Chain Holes

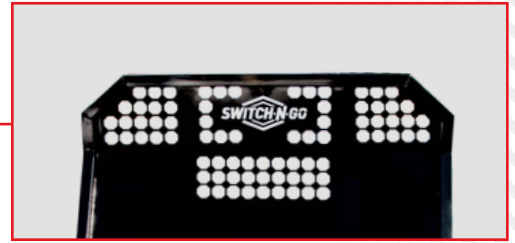
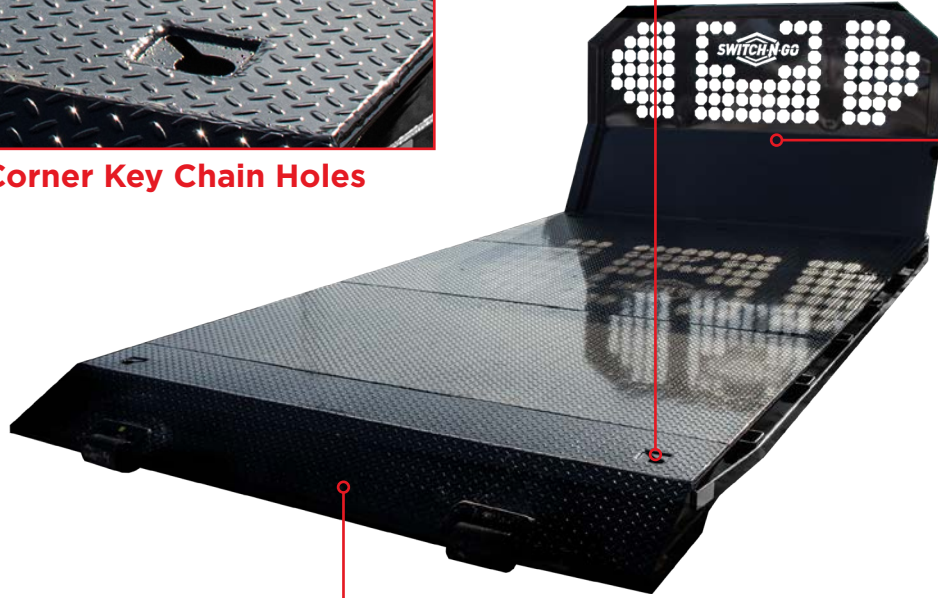

39" Height Bulkhead



51" Height Bulkhead



Available with or without Beavertail

SPECIFICATIONS

| | 9-12' LENGTHS | 13-15' LENGTHS |
|------------------------|--|---------------------|
| FLOOR | 1/8" DIAMOND PLATE | 3/16" DIAMOND PLATE |
| OUTER RAIL | 3" X 3" X 1/8" TUBING | |
| STAKE POCKETS | 24" ON CENTER | |
| RUB RAIL | 3/8" X 2" FLATBAR | |
| ROLLERS | INTEGRATED 4X6" WIDE GROUND ROLLERS | |
| CROSSMEMBERS | 3" STRUCTURAL CHANNEL ON 16" CENTERS | |
| KEYHOLES | LOCATED IN CORNERS OF PLATFORM FLOOR | |
| OPTIONS | WELDED D-RINGS / STAKE SIDES / NO BEAVERTAIL | |
| | STANDARD BULKHEAD | HIGH BULKHEAD |
| BULKHEAD WINDOW | ≈ 3.8 SQ FEET AREA | ≈ 4.4 SQ FEET AREA |

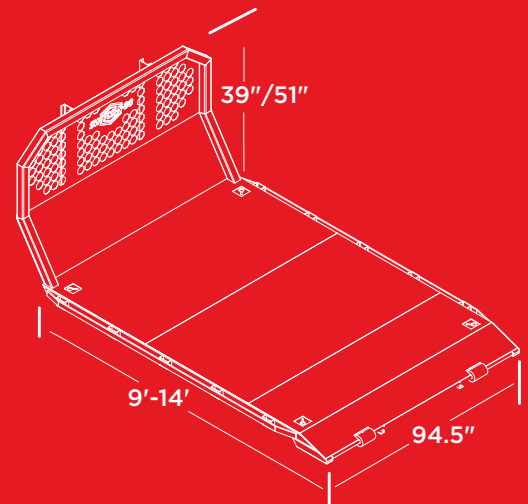

Specifications are subject to change without notice. For warranty information on this or any other Switch-N-Go® product please refer switchngo.com/warranty.



Subsidiary of Federal Signal Corporation

Interchangeable Truck Body System

LANDSCAPE BODY

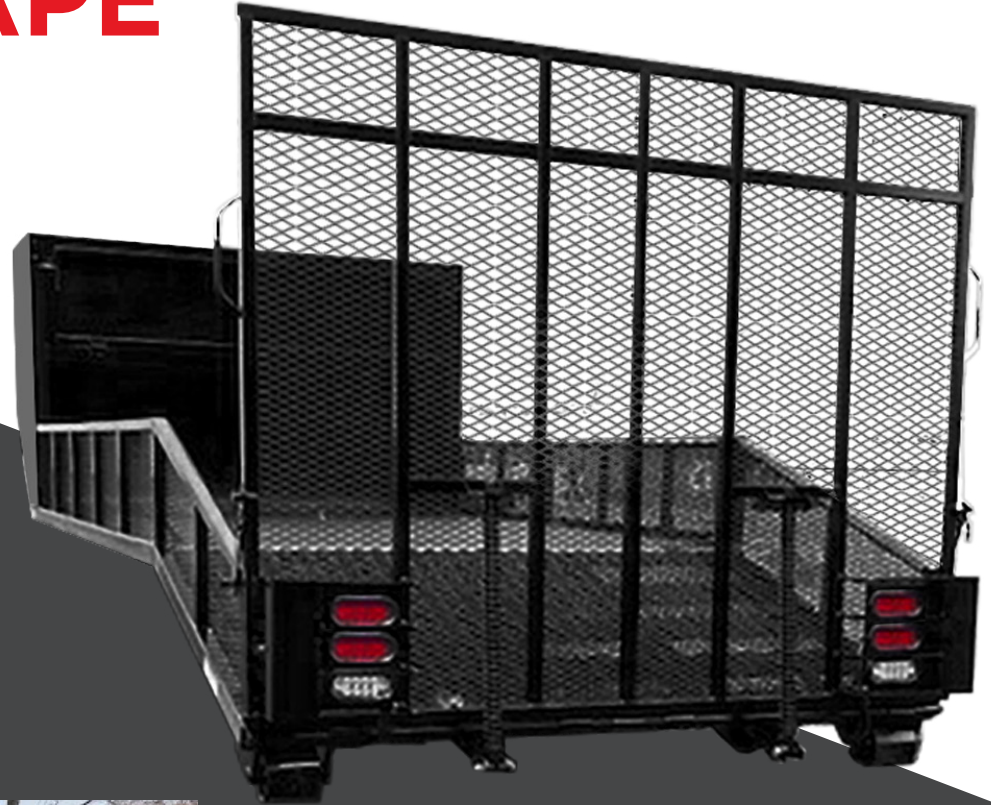

FEATURES

- Fold Down Ramp & Beaver Tail for efficient loading and unloading of equipment
- Passenger Fold down side
- 24" x 24" Lockable Top Compartment
- (4) D-Rings in corners for securing equipment
- Rear gate wired with LED lights
- High quality powder coated finish
- Available in 11', 12', and 14' lengths

FIND A DEALER IN YOUR AREA

[SWITCHNGO.COM/DEALER](https://www.switchngo.com/dealer)



Lockable Top Compartment



Passenger Fold Down Side

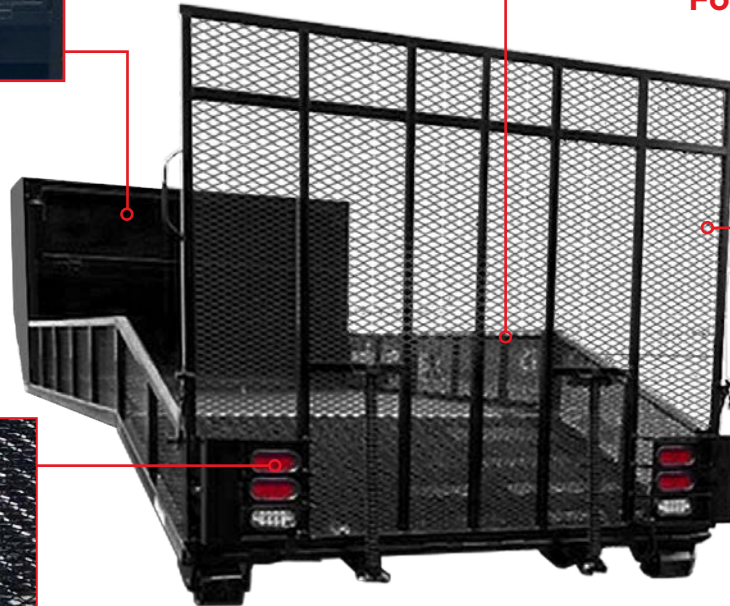

LED Tail Lights



Spring Assisted Fold Down Ramp

SPECIFICATIONS

| | 11' | 14' |
|----------------------------|---|-----|
| FLOOR | 11 GA DIAMOND PLATE | |
| RAMP | 11 GA EXPANDED METAL SPRING ASSISTED FOLD DOWN | |
| SIDES | 11 GA EXPANDED METAL | |
| SIDE HEIGHT | 16" | |
| CROSSMEMBERS | 12" ON CENTER | |
| D-RINGS | 4 IN CORNERS | |
| HOIST COMPATIBILITY | 11' | 14' |

*12' hoist compatible body available upon request

Specifications are subject to change without notice. For warranty information on this or any other Switch-N-Go® product please refer switchngo.com/warranty.

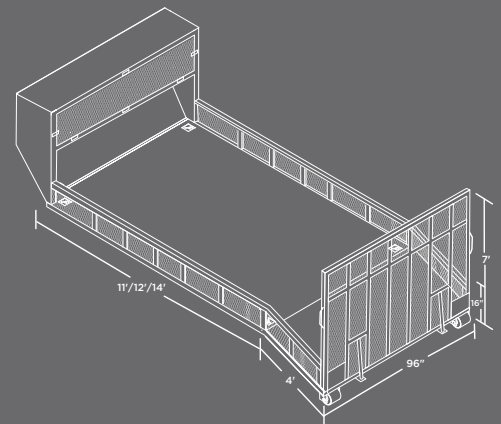



Subsidiary of Federal Signal Corporation

Interchangeable Truck Body System

STORAGE BODY



FEATURES

- High quality zinc prime & powder coated finish
- Lockable security-style doors
- 72" side height & 6" peak roof
- Standard 6" steel ground rollers
- Custom options available

FIND A DEALER IN YOUR AREA

SWITCHNGO.COM/DEALER



Standard Exterior Posts



Peak Roof



Internal Posts (optional)



Lockable Security Style Doors

SPECIFICATIONS

| | |
|----------------------|--|
| EXTERIOR POST | 12 GA WITH 5" FORMED POST ON 36-48" CENTER |
| INTERIOR POST | 3" STRUCTURAL CHANNEL |
| DOORS | LOCKABLE SECURITY STYLE WITH 3" X3" SUPPORTS |
| CROSSMEMBERS | 3" STRUCTURAL CHANNEL ON 16" CENTER |
| PEAK ROOF | 6" HIGH 12 GA SHEET |
| TOP RAIL | 3" X 3" X 1/8" TUBING |
| FLOOR | 10 GA SHEET |
| BULKHEAD | 12 GA SHEET |
| OPTIONS | INTERNAL SIDE POSTS / WELDED D-RINGS |

Specifications are subject to change without notice. For warranty information on this or any other Switch-N-Go® product please refer switchngo.com/warranty.

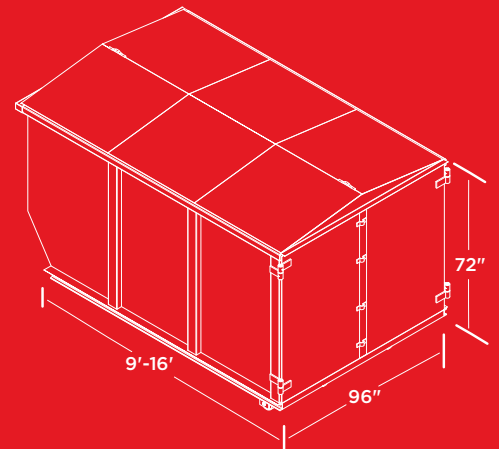



Subsidiary of Federal Signal Corporation

Interchangeable Truck Body System

VAN BODY

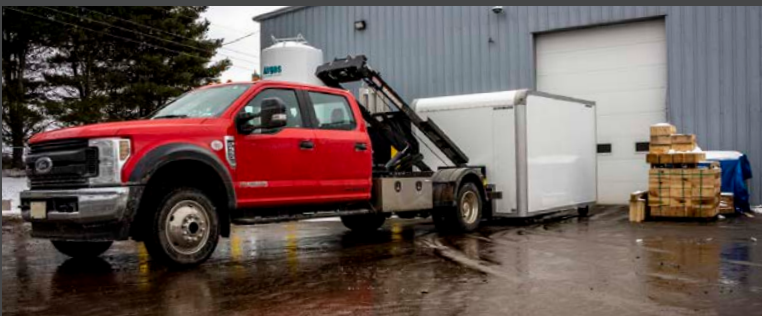

FEATURES

- Lightweight Design for Additional Payload
- Superior Corrosion Resistance
- Single Rear Roll-Up Door
- Fully Enclosed Unit for Cargo Protection
- Smooth Sides for Additional Advertising
- Available in 12', 13' & 15' lengths to be compatible with 11', 12' & 14' Switch-N-Go hoist systems.*

*Not compatible with S-Model

FIND A DEALER IN YOUR AREA

SWITCHNGO.COM/DEALER



Lockable Rear Roll-Up Door



Interior E-Track



Bolt-on Aluminum Pullout Ladder



Grab Handles

SPECIFICATIONS

| | 12' | 13' | 15' |
|-----------------------------|-----------------------------------|-----|-----|
| FLOOR | TONGUE & GROOVE EXTRUDED ALUMINUM | | |
| REAR ROLL-UP DOOR | 86"W X 77"H | | |
| INTERIOR SIDES | 1/2" PLYWOOD WITH E-TRACK | | |
| SIDE HEIGHT | 83" | | |
| CROSSMEMBERS | 12" ON CENTER | | |
| SYSTEM COMPATIBILITY | 11' | 12' | 14' |

Specifications are subject to change without notice. For warranty information on this or any other Switch-N-Go® product please refer switchngo.com/warranty.

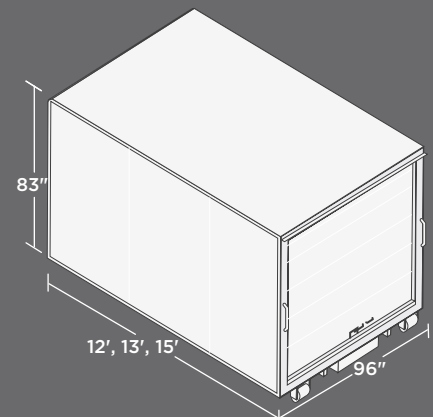



Interchangeable Truck Body System

Subsidiary of Federal Signal Corporation

SUBFRAME

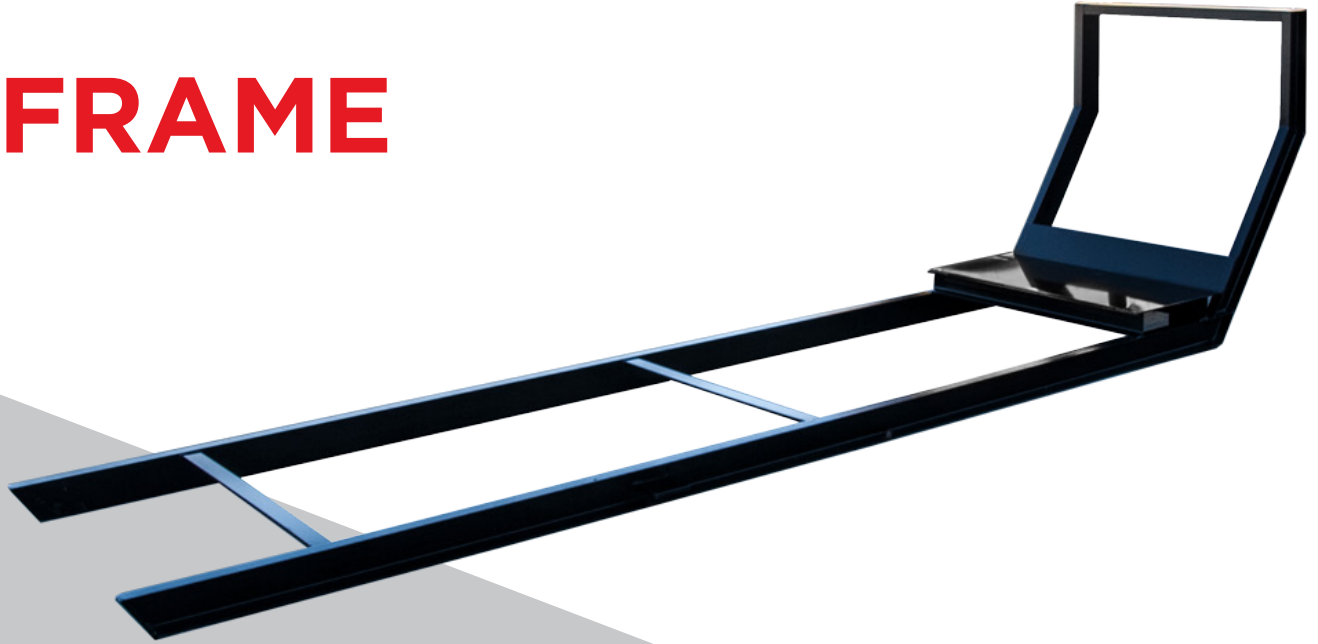

FEATURES

- High quality zinc prime & powder coated finish
- Lightweight design
- Rail Slides w/ no wheels
- Sloped front design for guaranteed operation with Switch-N-Go® system
- Ideal for custom usage upfits

FIND A DEALER IN YOUR AREA

SWITCHNGO.COM/DEALER

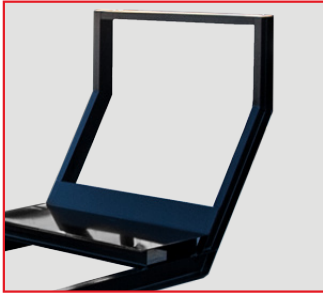

Sloped Front Design

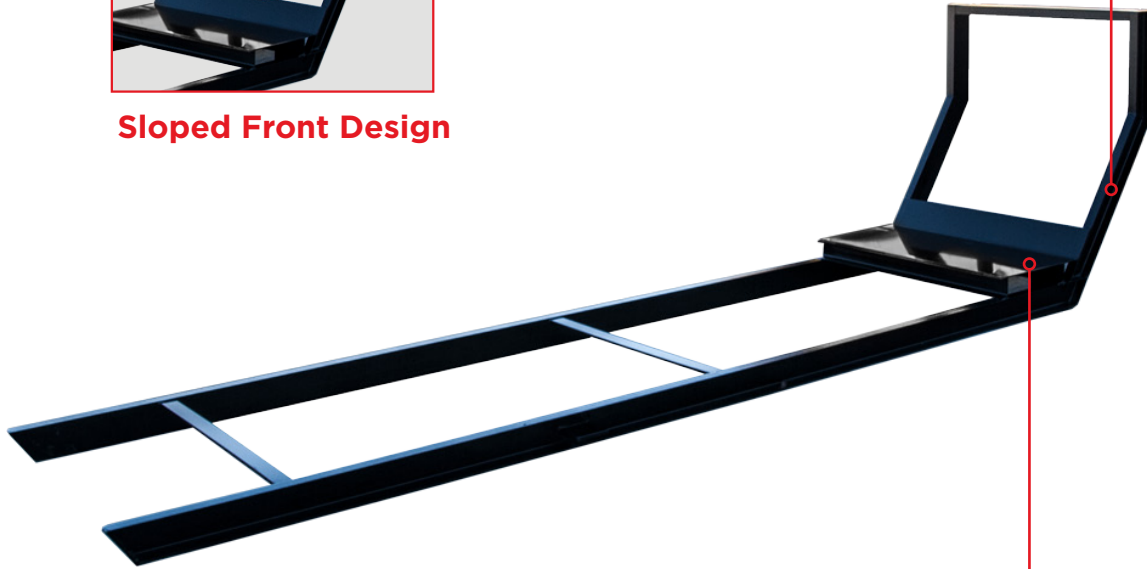

Reinforced Plate

SPECIFICATIONS

| | 11' SUBFRAME | 16' SUBFRAME |
|-----------------------------|---|-------------------|
| REINFORCED PLATE | 7 GA WITH PLATE AND 4" STRUCTURAL CHANNEL | |
| OUTER RAIL | 4" X 5.4# CHANNEL | 5" X 6.7# CHANNEL |
| CROSSMEMBERS | 3" STRUCTURAL CHANNEL ON 13" CENTERS | |
| SYSTEM COMPATIBILITY | 11' | 14' |

Specifications are subject to change without notice. For warranty information on this or any other Switch-N-Go® product please refer switchngo.com/warranty.

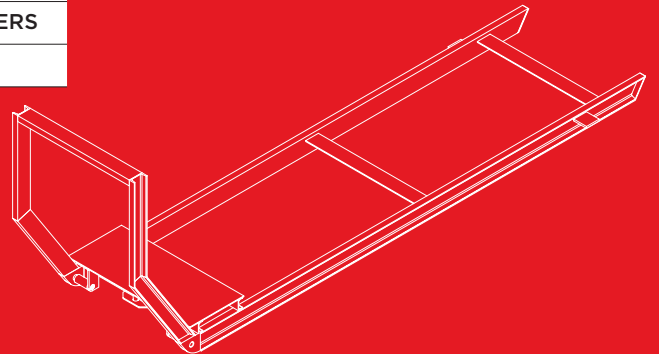



Subsidiary of Federal Signal Corporation

Interchangeable Truck Body System

WORKREADY™ SUBFRAME



FEATURES

- High quality zinc prime & powder coated finish
- Engineered to maximize legal payload
- Prevents material build-up with expanded metal cut-outs
- 16,500lb maximum load operation
- Simple framed bulkhead for visibility
- Non-slip surface with side cut-outs

FIND A DEALER IN YOUR AREA

SWITCHNGO.COM/DEALER



Retractable Legs

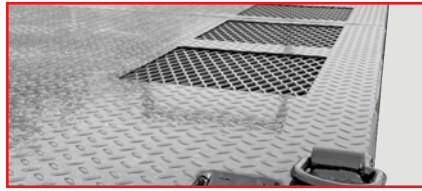

Expanded Metal Side-deck

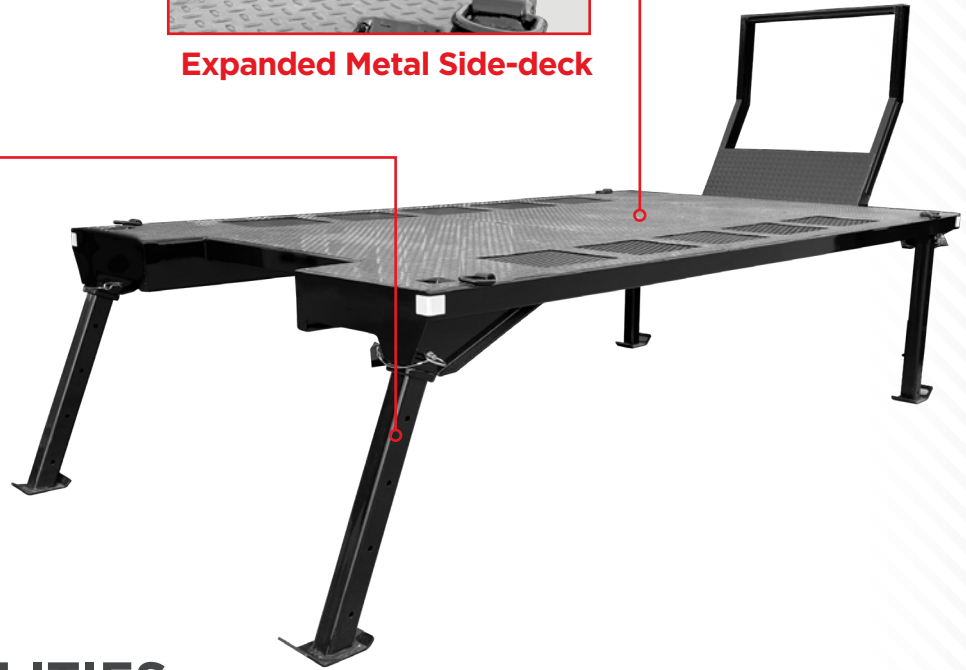

SEE THE POSSIBILITIES



Cold Mix / Patch



Sand Blaster / Compressor



Liquid Application



Material Sprayer



Seal / Asphalt Coating



Pavement Sweeper



Water or Liquid Tank



Hydroseeder



Fuel / Lube Unit



Pressure Washer



Sand / Salt Sprayer



Pavement Marking & Striping



Sewer Vacuum / Cleaner

SPECIFICATIONS

| | |
|----------------------------------|--|
| | 9' / 11' / 12' / 14' LENGTHS |
| MAXIMUM LOAD LIMIT | 16,500 LBS |
| ATTACHMENT POINTS | 4 D-RINGS RATED AT 4080 LBS LOCATED IN EACH CORNER |
| FLOOR | 1/8" DIAMOND PLATE WITH EXPANDED METAL FLOOR CUT-OUTS |
| LEGS | RETRACT AND STOW |
| 9' & 11' LENGTHS ONLY | 35 1/8" WIDE X 9" REAR CUTOUT |

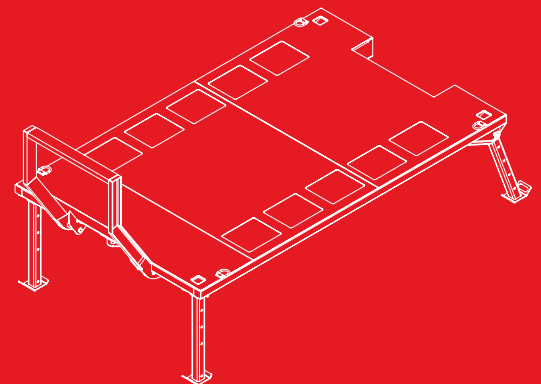

Specifications are subject to change without notice. For warranty information on this or any other Switch-N-Go® product please refer switchngo.com/warranty.



Subsidiary of Federal Signal Corporation

Interchangeable Truck Body System

SALT SPREADER BODY



FEATURES

- Superior Weight Distribution as compared to non-specialized upfits
- 4.8 Cubic Yard 304 Stainless Steel V-Box
- 12" Angled Front Extension
- 9" Rear Cutout for Conveyor
- Sloped Front Design
- Retractable Legs for interchangeability & storage without removing the chute
- 16,500lb maximum load operation
- Expanded metal subframe floor cut-outs to prevent material buildup

FIND A DEALER IN YOUR AREA

SWITCHNGO.COM/DEALER



9" Rear Cutout for Conveyor



12" Angled Front Extension

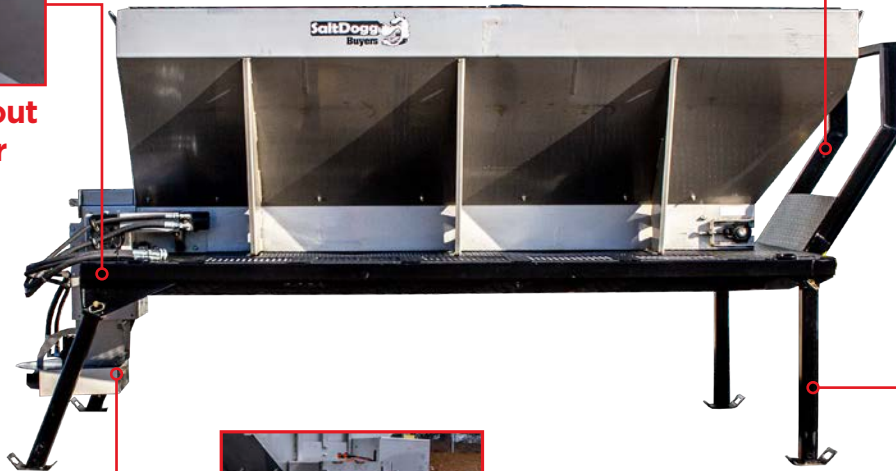

Available in Electric & Hydraulic Models

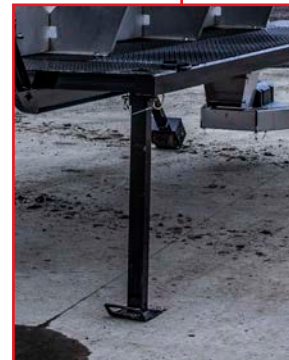

Retractable Legs

SPECIFICATIONS

| | 11' LENGTH ONLY | |
|---------------------------|---|--------------------|
| | ELECTRIC | HYDRAULIC |
| WORKING LOAD LIMIT | 16,500 LBS | |
| SPREADER CAPACITY | 4.8 YD | |
| ATTACHMENT POINTS | 4 D-RINGS RATED AT 4,080 LBS | |
| FLOOR | SIDE 19" WIDE EXPANDED METAL 3/4" CENTER 40" WIDE DIAMOND SHEET 1/8" | |
| REAR CUTOUT | 35 1/8" WIDE X 9" DEEP | |
| LEGS | UNPIN AND RETRACT | |
| SPREADER SPINNER | 1/2 HP, 12V MOTOR | DIRECT MOUNT HD |
| SPREADER CONVEYOR | 3/4 HP, 12V MOTOR | 20:1 WORM GEAR BOX |

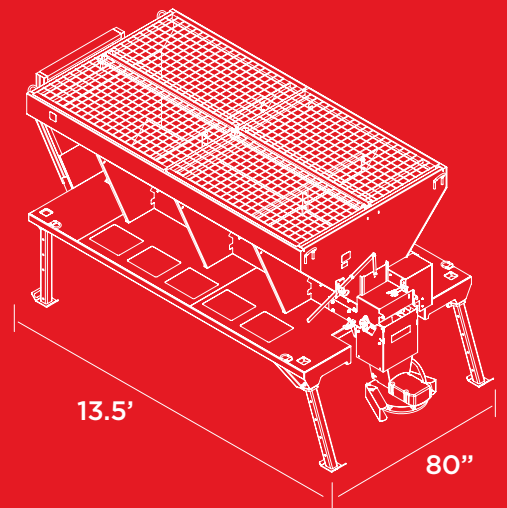

Specifications are subject to change without notice. For warranty information on this or any other Switch-N-Go® product please refer switchngo.com/warranty.



Interchangeable Truck Body System

Subsidiary of Federal Signal Corporation

11' FLATBED SERVICE BODY



FEATURES

- All Extruded 6005 T6 Alum Box Tube Construction
- T&G Extruded Alum Flooring
- Extruded Aluminum Headboard
- 3 Vertical Service Body Compartments per Side
- Rear Service Body Tailgate
- Powder Coated White
- Manual Master Lock System
- 2 Rows of E-Track Full Length

FIND A DEALER IN YOUR AREA

SWITCHNGO.COM/DEALER



Full Length E-Track



D-Rings



Customizable Storage Compartments



Master Lock System



SPECIFICATIONS

BODY DETAILS

| | |
|-----------------------------|--|
| FLOOR | T&G EXTRUDED ALUMINUM 102" LONG x 56 3/8" WIDE CENTER |
| TAILGATE | REAR SERVICE BODY TAILGATE |
| LATCHES | MANUAL MASTER LOCK SYSTEM |
| COMPARTMENTS | 3 PER SIDE - 40 3/16" W x 34 7/16" T WELDED TO FLATBED FLOOR |
| FLATBED CONSTRUCTION | G-TUBE PERIMETER / 2x3.125 CROSS MEMBERS, 12" OC / 2x3 .188 BOX TUBE LONG SILLS (GUSSETS EVERY 4' FROM FRONT TO BACK) / ALL EXTRUDED 6005 T6 ALUM / BOX TUBE CONSTRUCTION |
| BULKHEAD | EXTRUDED ALUMINUM HEADBOARD |
| D-RINGS | 6 RECESSED STAINLESS STEEL D-RING, SPRING-LOADED, 4.4K LB RATING, EVENLY SPACED, 3 PER SIDE |
| CARGO SECUREMENT | 2 ROWS OF E-TRACK FULL / CENTER BODY LENGTH |

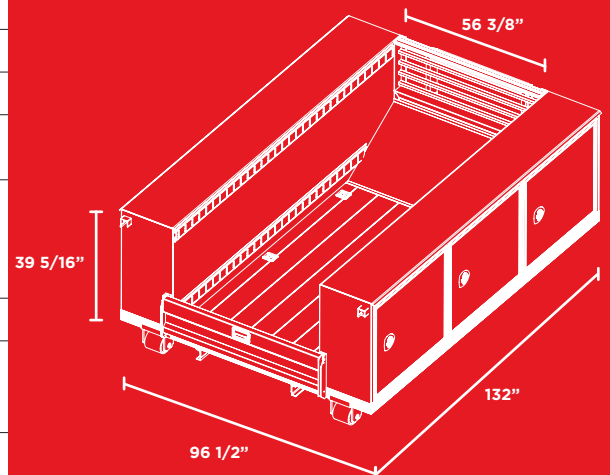

Specifications are subject to change without notice. For warranty information on this or any other Switch-N-Go® product please refer switchngo.com/warranty.



Interchangeable Truck Body System

Subsidiary of Federal Signal Corporation

RESIDENTIAL TRASH BODY



FEATURES

- 12GA structural steel construction
- 96x60” barn door tailgate standard
- Formed top rail
- Ideal for dumpster rental businesses

FIND A DEALER IN YOUR AREA

SWITCHNGO.COM/DEALER



Optional Tarp

Barn Doors



Flat Sides
A great place to advertise your business



Dual Locking Mechanism

SPECIFICATIONS

| BODY DETAILS | |
|---------------------|---|
| FLOOR | 12', 12GA SHEET |
| TAILGATE | 60" BARN DOOR: 2" x 2" x 1/8" TUBULAR FRAME WORK FORMED |
| SIDE | 12GA SHEET SMOOTH |
| CROSSMEMBERS | 3" x 3.5# STRUCTURAL CHANNEL AND FORMED CHANNEL ON 16" CENTERS, FORMED TOP RAIL |
| CAPACITY | 18 CUBIC YARDS |
| PAINT | POWDER BLACK (WILL QUOTE OTHER COLORS) |

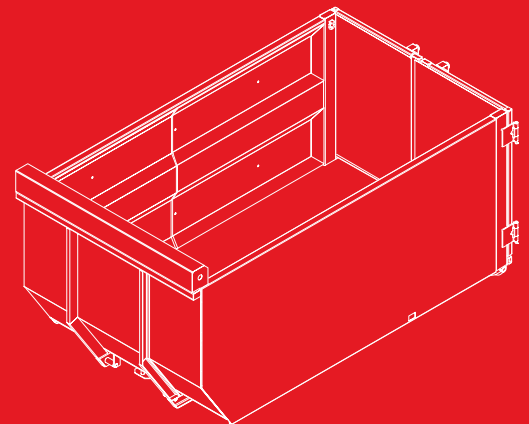

Specifications are subject to change without notice. For warranty information on this or any other Switch-N-Go® product please refer switchngo.com/warranty.



Subsidiary of Federal Signal Corporation

Interchangeable Truck Body System

STORAGE CONTAINER



FEATURES

- **Two Lengths:** 12' for 11' and 12' systems and 16' for 14' systems
- **Base/Frame:** Powder coated steel
- **Walls:** 0.8 mm flat lightweight powder coated steel panel
- **Roof:** 14 Ga powder coated rolled steel
- **Floor:** 19 mm plywood with waterproof fiber coating front and back
- **Doors:** Rear double swing with 72"W x 78"H opening

FIND A DEALER IN YOUR AREA

SWITCHNGO.COM/DEALER



Ships folded and collapsed, assembly required



**Switch-N-Go®
Subframe included**
(ships separately)



SPECIFICATIONS

| | 12' | 16' |
|------------------------|---------------------|---------------------|
| EXTERIOR | 144"L X 93"W X 96"H | 192"L X 93"W X 96"H |
| INTERIOR | 140"L X 90"W X 91"H | 188"L X 90"W X 91"H |
| FOLDED HEIGHT | 17" | 15" |
| SIZE CAPACITY | 665 CU FT | 895 CU FT |
| WEIGHT CAPACITY | 7,000 LBS | 10,000 LBS |
| BODY WEIGHT | 2,200 LBS | 2,500 LBS |

Specifications are subject to change without notice. For warranty information on this or any other Switch-N-Go® product please refer switchngo.com/warranty.

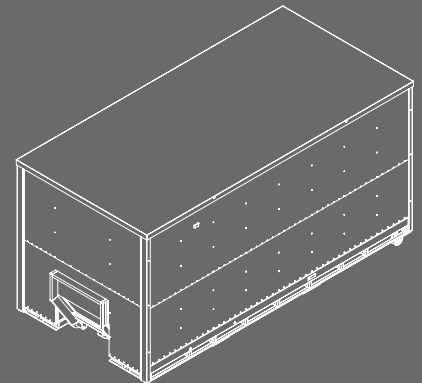



Interchangeable Truck Body System

Subsidiary of Federal Signal Corporation

RECYCLER BODY



FEATURES

- High quality zinc prime & powder coated finish
- Standard 6" steel ground rollers
- Roof with two slider lids per side (4 sliders total)
- Roof also available to be purchased separately

FIND A DEALER IN YOUR AREA

SWITCHNGO.COM/DEALER



29" Gambrel Roof



**30" x 30" Sliding Lids
(2 per Side)**



**96" Outside Floor
Width**



SPECIFICATIONS

| | |
|-------------------------|---|
| FLOOR | 10 GA, 96" WIDE X 11' LONG |
| SIDE POSTS | 2-3 POSTS PER SIDE PER SIDE, 12 GA SHEET |
| CROSSMEMBERS | 3" STRUCTURAL CHANNEL 16" ON CENTER |
| TOP RAIL | FORMED 12 GA |
| TAILGATE | FORMED 12GA STEEL SHEET WITH 2" X 2" X 1/8" TUBULAR FRAME WORK |
| SIDE HEIGHT | 39" |
| SIDES/FRONT | 12 GA SHEET |
| REAR CORNER POST | 7 GA SHEET |
| GAMBREL ROOF | 29" |
| SLIDING LIDS | 2 PER SIDE / 30" EACH |

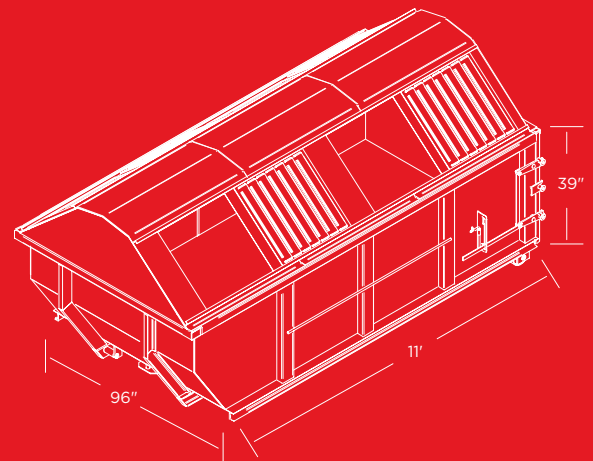

Specifications are subject to change without notice. For warranty information on this or any other Switch-N-Go® product please refer switchngo.com/warranty.



Switch-N-Go®
**PRODUCT
SPEC SHEETS**

<https://sng1.page.link/download>



Switch-N-Go®
**AUTHORIZED
DEALER LOCATOR**

www.switchngo.com/find-a-dealer

